

REVISIONS			
REV.	DESCRIPTION	DATE	DCN NO
-	FOR QUOTING PURPOSES ONLY		

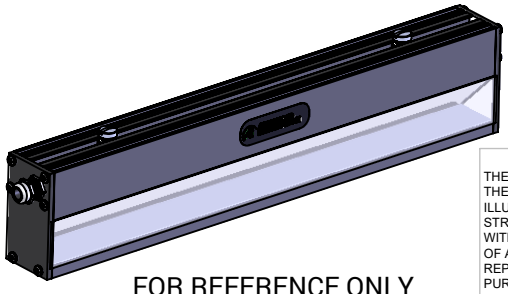
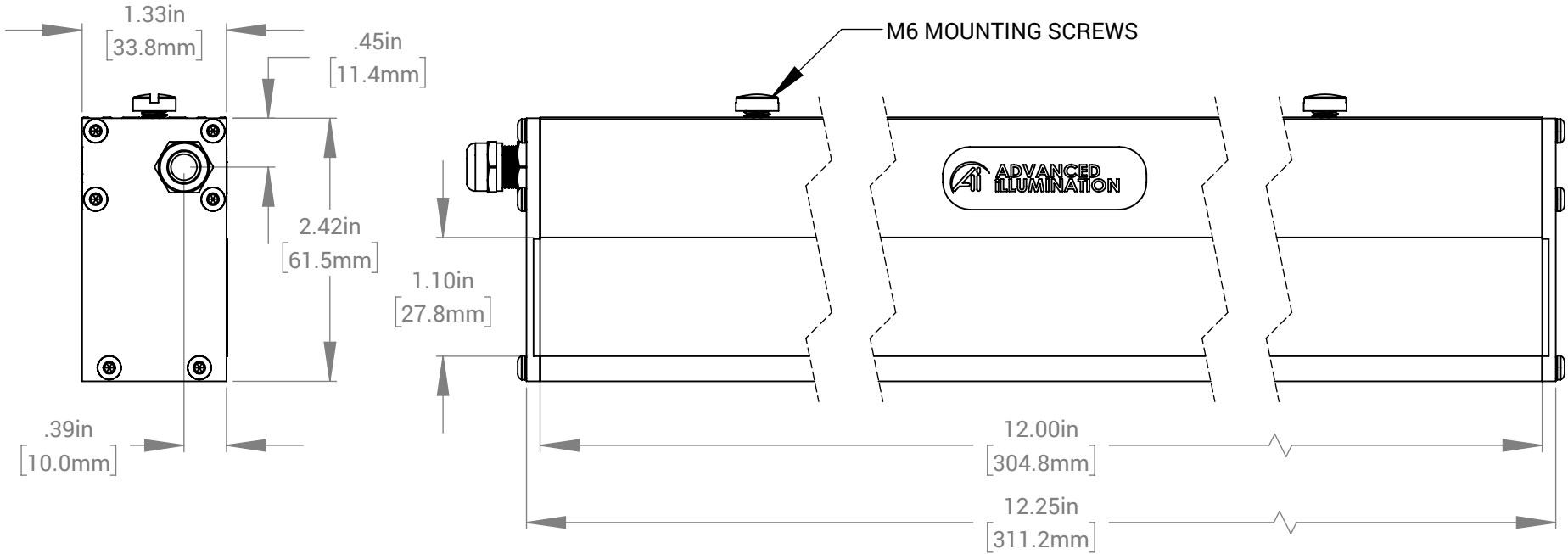
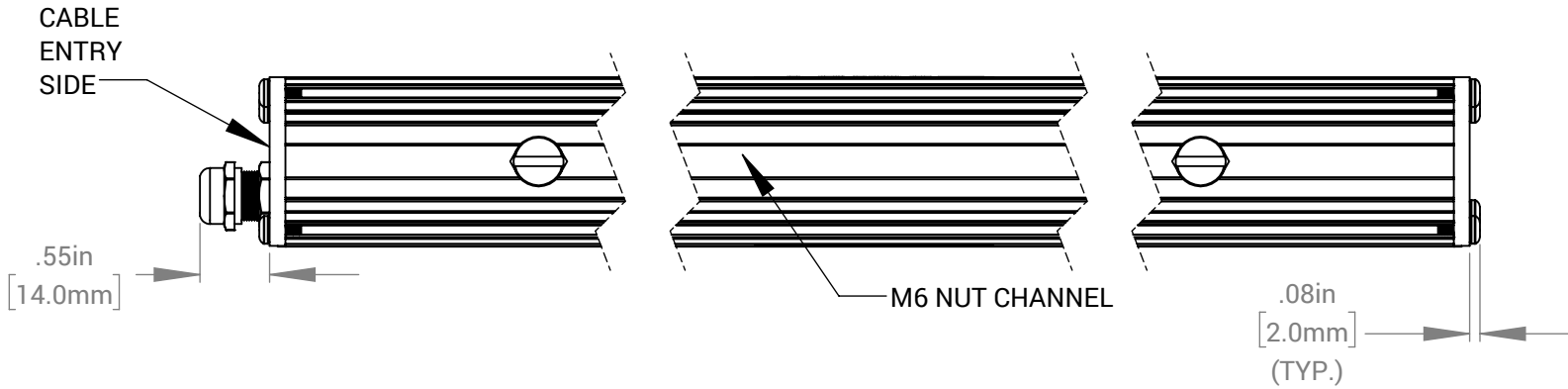

FOR REFERENCE ONLY

**PROPRIETARY AND CONFIDENTIAL**  
 THESE DRAWINGS AND SPECIFICATIONS ARE THE EXCLUSIVE PROPERTIES OF ADVANCED ILLUMINATION INCORPORATED ISSUED IN STRICT CONFIDENCE AND SHALL NOT, WITHOUT THE PRIOR WRITTEN PERMISSION OF ADVANCED ILLUMINATION INC BE REPRODUCED, COPIED OR USED FOR ANY PURPOSE WHATSOEVER EXCEPT THE MANUFACTURE OF ARTICLES FOR ADVANCED ILLUMINATION INC

**UNIT WEIGHT: 1.24 lbs**

CUT USING: -		UNLESS OTHERWISE SPECIFIED:	DATE	NAME	 440 STATE GARAGE ROAD, ROCHESTER, VERMONT 05767
		SURFACE SHOULD BE FREE OF SCRATCHES, BURRS, AND DENTS	30-MAR-21	Ai	
		DIMENSIONS ARE IN: INCHES	CHECKED	--	TITLE: DRAWING, INSTALLATION, DL110
		<u>TOLERANCES</u>	APPROVED	--	
		FRACTIONAL: 1/16	MATERIAL		SIZE DWG. NO. REV <b>A</b> DL110 -
		ANGULAR: MACH ± 1 BEND ± 1	FINISH		
		TWO PLACE DECIMAL ± .010			SCALE: NTS/C CODE: - SHEET 1 OF 1
		THREE PLACE DECIMAL ± .005			
NEXT ASSY	USED ON	MAKE FROM			
APPLICATION					