

AL150 LENGTH MATRIX

PART #	LENGTH IN INCHES (mm)
AL150006	1.62 (41.1 mm)
AL150012	2.64 (67.0 mm)
AL150018	3.66 (92.9 mm)
AL150024	4.68 (118.8 mm)
AL150030	5.70 (144.8 mm)
AL150036	6.72 (170.7 mm)
AL150042	7.74 (196.6 mm)
AL150048	8.76 (222.5 mm)
AL150054	9.78 (248.4 mm)
AL150060	10.80 (274.3 mm)
AL150066	11.82 (300.2 mm)

SEE WEBSITE FOR ADDITIONAL SIZE OPTIONS

REVISIONS			
REV.	DESCRIPTION	DATE	DCN NO
-	FOR QUOTING PURPOSES ONLY		

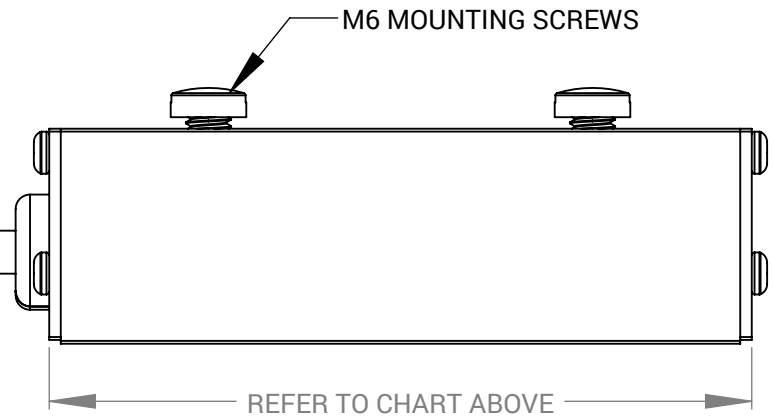
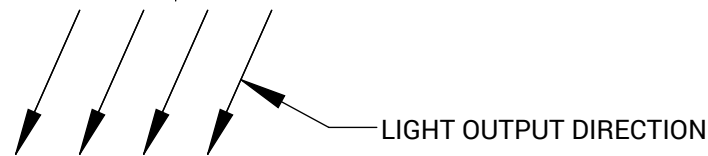
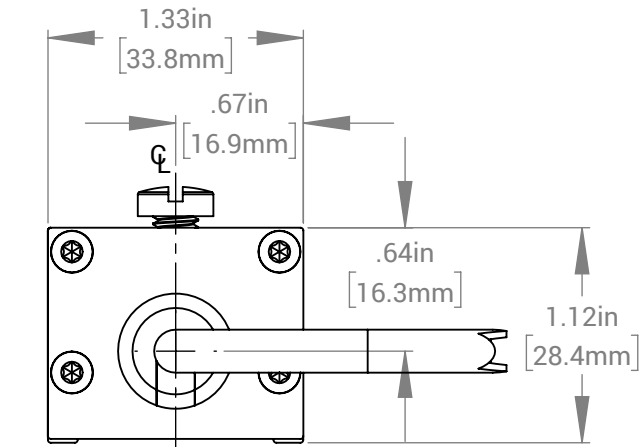
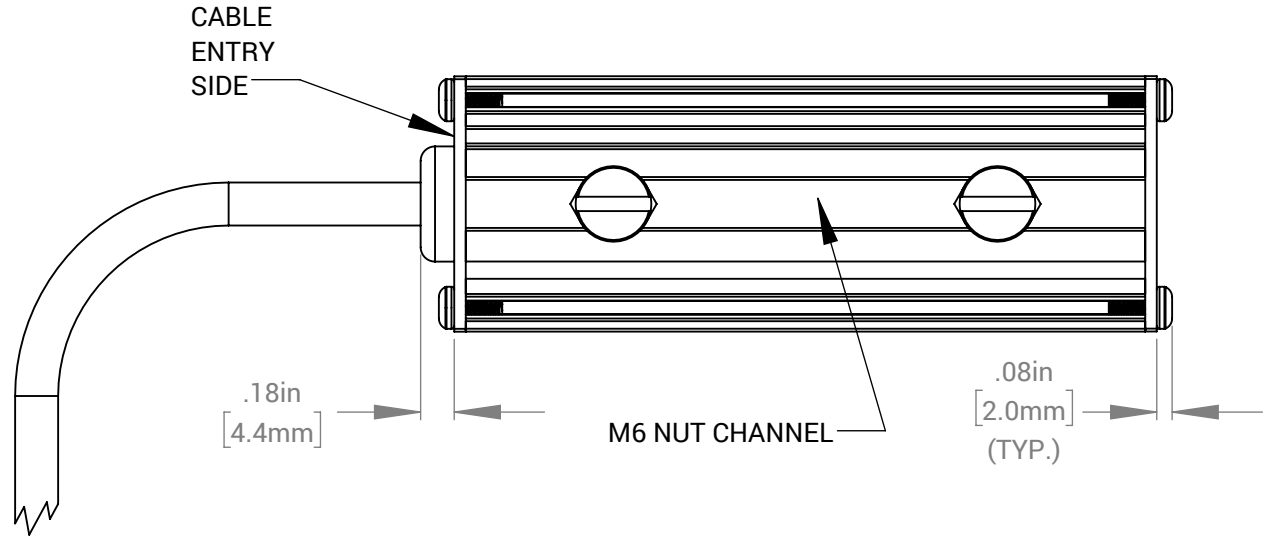

1.6" UNIT WEIGHT: .43 lbs

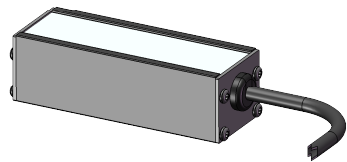

FOR REFERENCE ONLY

PROPRIETARY AND CONFIDENTIAL
 THESE DRAWINGS AND SPECIFICATIONS ARE THE EXCLUSIVE PROPERTIES OF ADVANCED ILLUMINATION INCORPORATED ISSUED IN STRICT CONFIDENCE AND SHALL NOT, WITHOUT THE PRIOR WRITTEN PERMISSION OF ADVANCED ILLUMINATION INC BE REPRODUCED, COPIED OR USED FOR ANY PURPOSE WHATSOEVER EXCEPT THE MANUFACTURE OF ARTICLES FOR ADVANCED ILLUMINATION INC

CUT USING:		UNLESS OTHERWISE SPECIFIED:	DATE	NAME	 440 STATE GARAGE ROAD, ROCHESTER, VERMONT 05767
		SURFACE SHOULD BE FREE OF SCRATCHES, BURRS, AND DENTS	16-NOV-18	T.MILLS	
		DIMENSIONS ARE IN: INCHES			TITLE:
		<u>TOLERANCES</u>			DRAWING, INSTALLATION, AL150
		FRACTIONAL: 1/16			SIZE
		ANGULAR: MACH ± 1 BEND ± 1			DWG. NO.
		TWO PLACE DECIMAL ± .010			AL150
		THREE PLACE DECIMAL ± .005			REV
		MAKE FROM			-
NEXT ASSY	USED ON	FINISH			SCALE: NTS C CODE: -
					SHEET 1 OF 1